

TOP VIEW

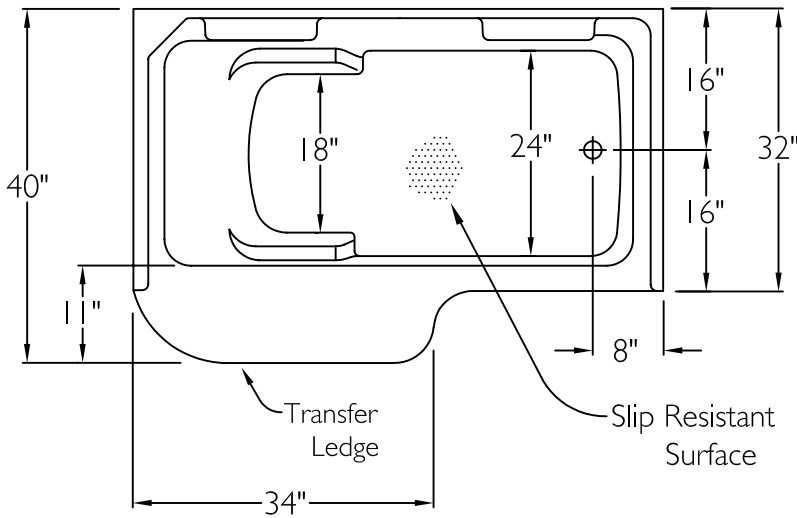

FRONT VIEW

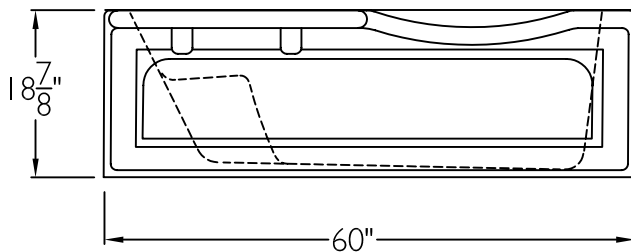

SIDE VIEW

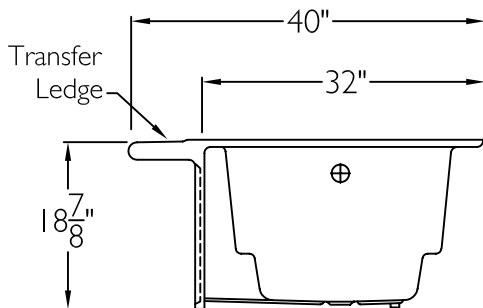

SUBMITTAL

This molded bathtub shall be model XSA 6034 TO TL left or right. Finished surface shall be of a sanitary grade acrylic exhibiting a minimal thickness of 15 dry mils and a finished cured Barcoal hardness of 80-90 as tested with ASTM D-2583. Unit construction shall be of a molded reinforced fiberglass with a 15% minimum fiberglass content.

The unit shall have outside dimensions of 60" x 32" x 18 7/8" (40" to edge of transfer ledge). The unit shall meet ANSI Z124.1-2, BOCA, NAHB, UPC, CSA, and shall meet the requirements of the Southern Building Code.

The enclosure shall be equipped with the following accessories:
 1) integral molded apron, skirt, 2) molded arm rests, 3) large molded transfer ledge, 4) right or left hand drain, 5) recess style bathtub with integral molded mounting edge along both sides and the back.

THIS UNIT FEATURES THE OUTSIDE DIMENSION OF 60 OF OVERALL WIDTH, THIS DOES NOT ALLOW FOR FULL ENCLOSURE OF THE BOLTS AND NUTS USED TO SECURE THE BARS AND SEAT IN PLACE. THE BOLT AND NUT COMBINATION SHOULD NOT PROTRUDE MORE THAN 3/4" ON EITHER SIDE OF THE SHOWER WALLS. THIS MAY REQUIRE THE NEED TO NOTCH STUDS TO ALLOW BOLT CLEARANCE FOR A DRYWALL ENCLOSED FIRE WALL INSTALLATION. ADJUSTMENT OF THE WALL BOARD MAY BE NECESSARY TO PROVIDE CLEARANCE OF THE BOLT(S) WHILE MAINTAINING THE INTEGRITY OF THE DRYWALL ENCLOSED FIRE WALL ENCLOSURE.

NOTE: THIS UNIT WILL NOT ACCEPT A DOOR.

Job Name	Approved By	Name	Date	COMFORT DESIGNS		
Project No	Architect			Model No. XSA 6034 TO TL-I		
Comfort Designs 435 Industrial Road Savannah, TN 38372 tel 800,443,7269 fax 731,925,4290 www.comfortdesignsbathware.com	Engineer			Drawing No. XSA 6034 TO TL		
	Rep			Date Issued, 4-9-12	Drawing Rev.	
	Wholesaler			Material. Acrylic		
	Comments			Color,		
				Dimensions are in inches. Due to the nature of the materials dimensions may vary ± 1/2"		